

XS4 Locker

SALTO
inspiredaccess

- Eng Installation guide
E Guía de instalación
F Guide d'installation
D Montageanleitung

Li 050xx series

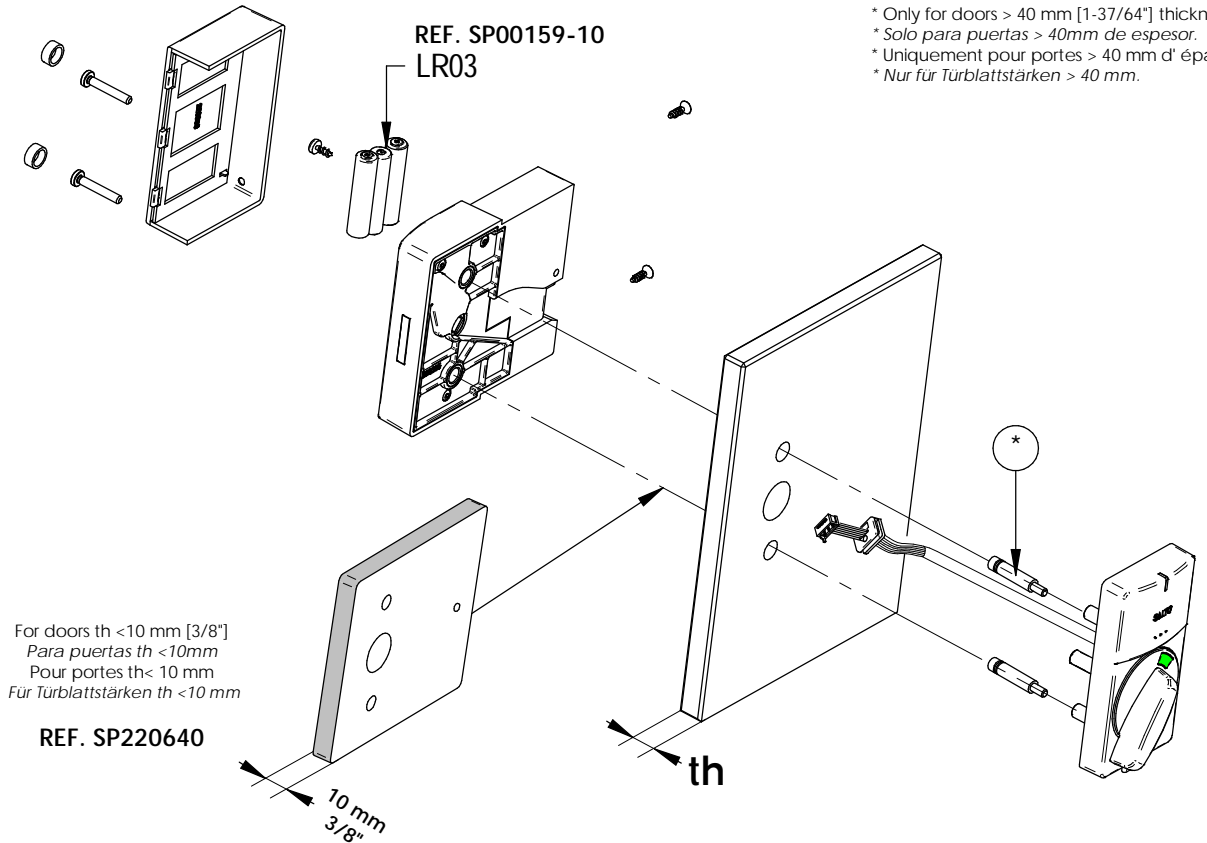
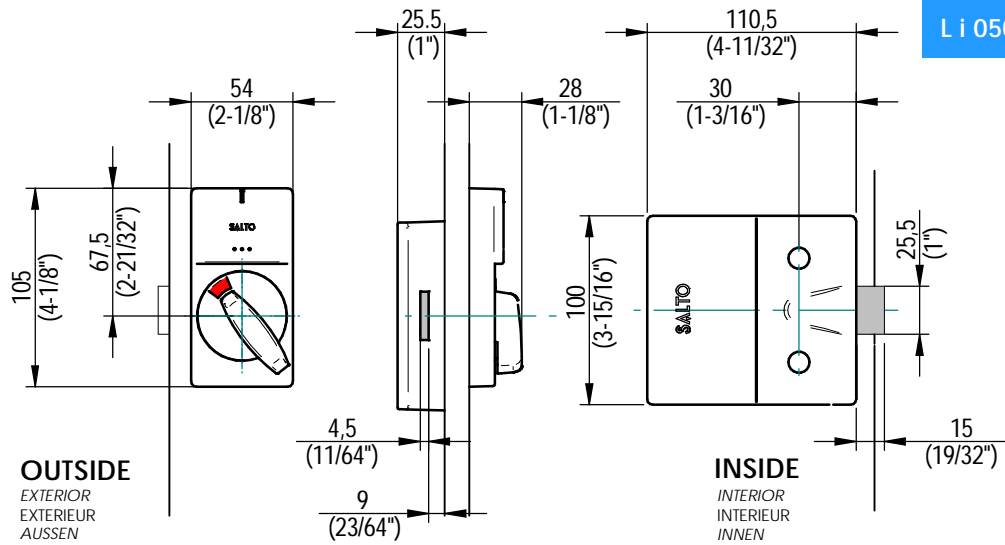
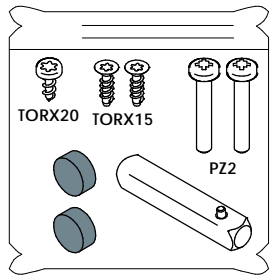

L "L" MOUNTING
MONTAJE "L"
MONTAGE "L"

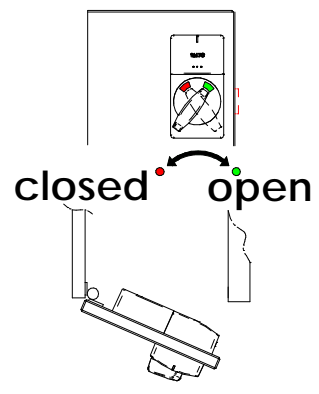

R "R" MOUNTING
MONTAJE "R"
MONTAGE "R"

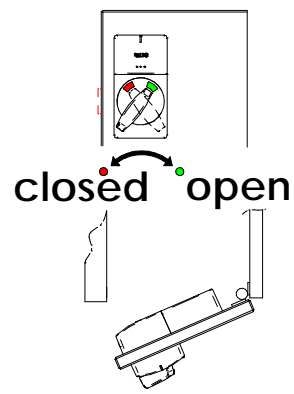

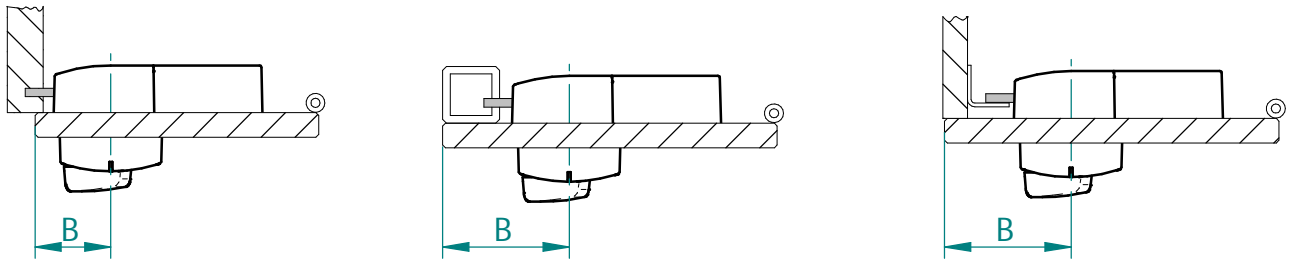

- (Eng) The dimension B will depend on the door or strike type the locker lock is going to be installed on.
- (E) La cota B dependerá en cada caso del tipo de puerta o cerradero donde se instale la cerradura de taquilla.
- (F) La mesure B dépendra dans chaque cas du type de porte ou gâche où va s'installer la serrure vestiaire.
- (D) Maß B ist abhängig von Tür-oder Schließblechart, an der das Schrank-/Kabinenschloss installiert wird.

(Eng) Installation (E) Instalación (F) Installation (D) Montageanleitung

1

OUTSIDE
EXTERIOR
EXTERIEUR
AUSSEN

INSIDE
INTERIOR
INTERIEUR
INNEN

7 mm [1/4"] deep, Hole only inside.
Agujero solo por el interior. 7 mm de prof.
Trou de 7 mm profondeur par l'intérieur.
7mm tiefe Lochung nur innen.

¡klik!

3

"L" MOUNTING
MONTAJE "L"
MONTAGE "L"

"R" MOUNTING
MONTAJE "R"
MONTAGE "R"

Guide wire through the slot!
Guiar cable a través de la ranura!
Guidez le fil dans la fente!
Datenkabel durch die Öffnung führen!

Max. torque
1,5 Nm

4

Fasten with screw to keep it aligned.
Fijar el tornillo para mantener el alineamiento.
Fixer la vis pour assurer l'alignement.
Schraube fixieren, um Ausrichtung beizubehalten.

5

Caution!
Atención!
Attention!
Achtung!

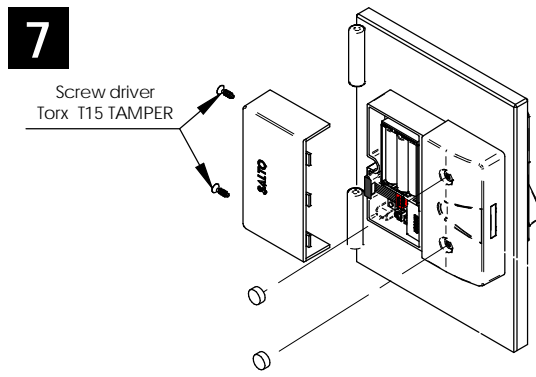
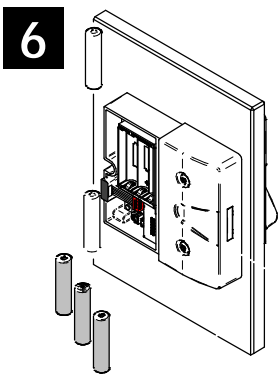

**AT THIS POINT DO NOT CLOSE THE DOOR
PROGRAM XS4 Locker FIRST**

Check operation with a construction card.

NO CIERRE LA PUERTA. PROGRAME LA XS4 Locker

Compruebe funcionamiento con llave de obra.

**NE FERMEZ PAS LA PORTE.
PROGRAMMEZ LA XS4 Locker AVANT**

Vérifiez le bon fonctionnement avec la carte de construction

**TÜRE NICHT SCHLIESSEN.
ZUERST XS4 Locker PROGRAMMIEREN**

Überprüfen Sie die Funktion mit der Construction Card

- Eng Electrical characteristics
- E Características eléctricas
- F Caractéristiques électriques
- D Elektrische Eigenschaften

OPERATING CHARACTERISTICS			
	Min.	Max.	Unit
Temperature	0	60	°C
Humidity	0	95	%

RF CHARACTERISTICS				
	Min.	Cent.	Max.	Unit
RFID Frequency	-	13,56	-	MHz
Bluetooth Smart Frequency *	2400	2445	2483,5	MHz

POWER SUPPLY		
Batteries		Unit
3xLR03	4,5	V

Condiciones ambientales			
	Min.	Max.	Unidad
Temperatura	0	60	°C
Humedad	0	95	%

CARACTERÍSTICAS RF				
	Min.	Cent.	Max.	Unit
Frecuencia RFID	-	13,56	-	MHz
Bluetooth Smart Frequency *	2400	2445	2483,5	MHz

FUENTE DE ALIMENTACIÓN		
Batteries		Unit
3xLR03	4,5	V

CONDITION DE FONCTIONNEMENT			
	Min.	Max.	Unité
Température	0	60	°C
Humidité	0	95	%

RF CARACTERISTIQUES				
	Min.	Cent.	Max.	Unit
Fréquence RFID	-	13,56	-	MHz
Bluetooth Smart Frequency *	2400	2445	2483,5	MHz

SOURCE DE COURANT		
Batteries		Unit
3xLR03	4,5	V

OMGEVING			
	Min.	Max.	Einheit
Temperatur	0	60	°C
Luftfeuchtigke	0	95	%

RF EIGENSCHAFTEN				
	Min.	Cent.	Max.	Unit
RFID Frequenz	-	13,56	-	MHz
Bluetooth Smart Frequency *	2400	2445	2483,5	MHz

ENERGIEVERSORGUNG		
Batteries		Unit
3xLR03	4,5	V

- Eng Installation and use recommendations
- E Consejos de uso e instalación
- F Recommendations d'utilisation et d'instalation
- D Empfohlene Handhabung und installation

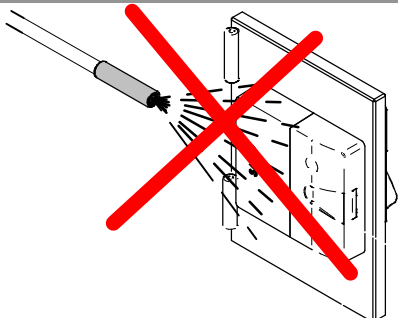

- Eng **DO NOT CLEAN WITH PRESSURE WATER**
- E **NO LIMPIAR CON AGUA A PRESIÓN**
- F **NE PAS NETTOYER À L'EAU SOUS PRESSION**
- D **NICHT MIT DRUCKWASSER REINIGEN**

- Eng In case the device is surrounded by metal surfaces or metallic environment, radio performance could be seriously affected.*
- E En caso de que el dispositivo esté rodeado de superficies metálicas o entorno metálico, el rendimiento de radio podría verse seriamente afectado.*
- F Dans le cas où l'équipement est entouré de surfaces métalliques ou d'un environnement métallique, les performances radio peuvent être sérieusement affectées.*
- D Wenn das Gerät von Metall umgeben oder abgedeckt ist, kann die Funkleistung erheblich beeinträchtigt werden.*

(*) Not apply to models: / No aplica a los modelos: / Ne applique pas aux modèles: / Gilt nicht für Modelles: L8050xx..

- Eng Signalling
- E Señalética
- F Signalisation
- D Signale

Access granted Apertura normal Accès accordé Zutritt gewährt	Access denied Rechazo Accès refusé Zutritt verweigert	Low battery Pilas bajas Pile faible Niedriger Batteriestand	Battery change Cambio de pilas Remplacement de la pile Batteriewechsel
<p style="color: green; font-weight: bold;">BEEEEEP</p>	<p style="color: red; font-weight: bold;">BEEP BEEP BEEP BEEP BEEP BEEP BEEP BEEP</p>	<p style="color: red; font-weight: bold;">BEEP BEEP BEEP BEEP</p>	<p style="color: yellow; font-weight: bold;">BEEP BEEP BEEP</p>

XS4 Locker

SALTO
inspiredaccess

Office mode notice
Puesta en paso
Notice du Mode Office
Office-Modus aktiviert

Office mode end
Fin paso
Fin du mode office
Office-Modus deaktiviert

BEEP
BEEP



BEEP

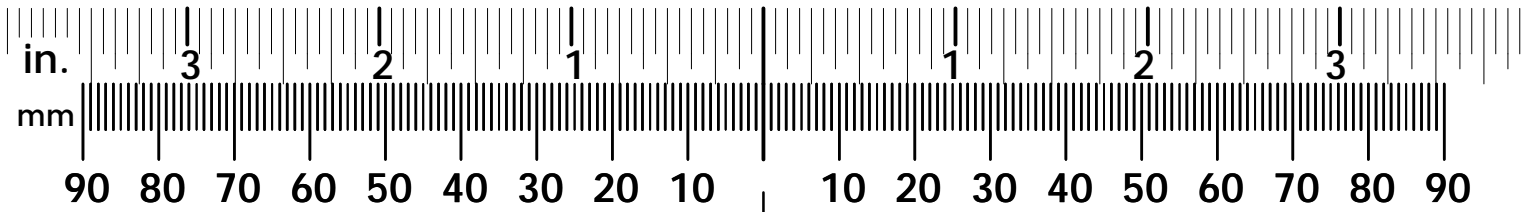
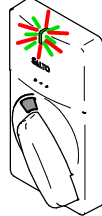

7 mm [1/4"] deep, Hole only inside.
Agujero solo por el interior. 7 mm de prof.
Trou de 7 mm profondeur par l'interieur.
7mm tiefe Lochung nur innen.

7 mm [1/4"] deep, Hole only inside.
Agujero solo por el interior. 7 mm de prof.
Trou de 7 mm profondeur par l'interieur.
7mm tiefe Lochung nur innen.

Reader/ Lector /Lecteur /Leser

Control / Steuereinheit
MONTAJE "R"
MONTAGE "R"
"R" MOUNTING

Control / Steuereinheit
MONTAJE "L"
MONTAGE "L"
"L" MOUNTING

